

Lectern

University of Toronto Standard Classroom Lectern
(shown: custom built lectern for OSM)

One supplied for every classroom
Lightweight portable stand for lecture notes
Height adjustable
Non-powered

To be used in conjunction with Teaching Station or Teaching Station Jr.

Configuration

15 degree surface tilt
Top 24" wide by 15" high
Tripod base with non-adjustable feet (NOT four points with adjustable feet)
Adjustable height range approx 2'6 - 3'6 to unit surface centre
Height adjustment a squeeze-cam of some type (NOT a screw that pushes into internal post)
*All fixed metal connections welded; no bolt connections
Lip $\frac{3}{4}$ " above surface

Finish

Wood top, clear finish
Black or dark warm grey metal legs

Provisioning

*depends on project. Suggested provisioning:
Client supplied
Client Installed



* all dimensions approximate
subject to change by builder

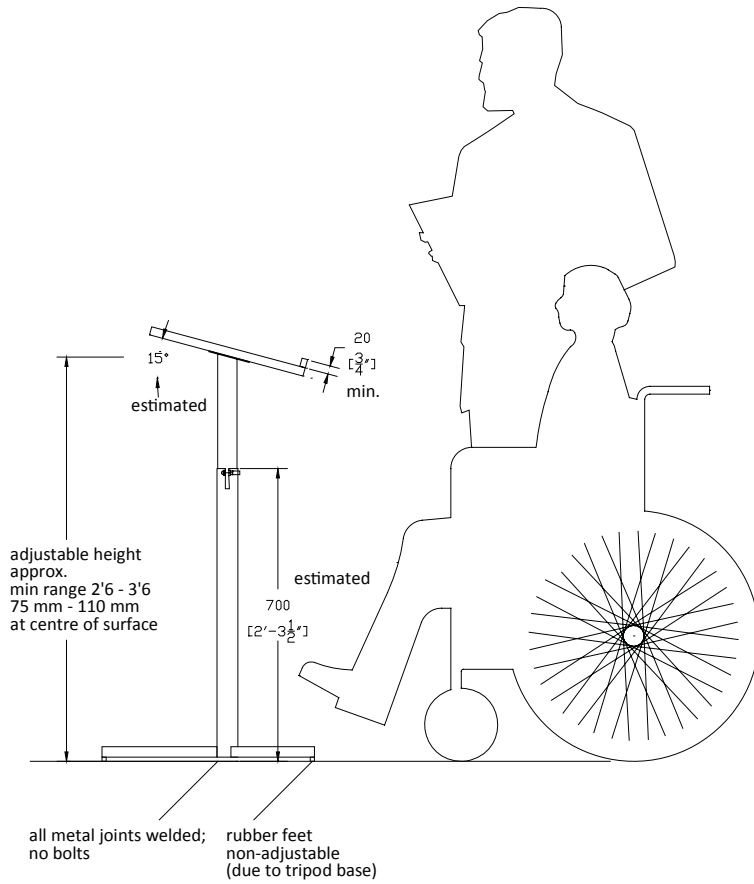
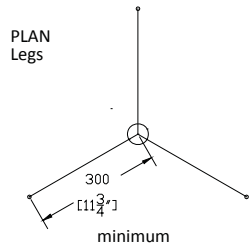
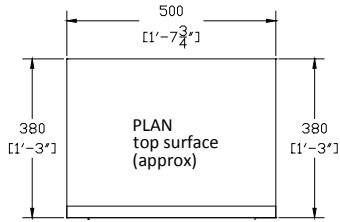

FINISH
all metal: black or dark grey
wood: fine grain
stain clear (none) or medium
durable topcoat all sides

Clamp - NOT TO SCALE

requirements:

- secures tight
- large easy to grab knob / clamp
- no open areas where fingers could be pinched
- long term durability
- prefer clamp that squeezes post, as in a bicycle seat clamp, as opposed to a threaded bold which drives into the side of the interior post

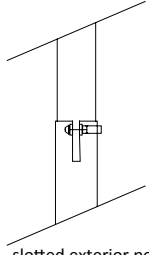

like this
(clamp - bicycle style)



or this (knob)



slotted exterior post
squeezes interior post